

外壁落下事故から あなたの資産を 守ります!!

ビル・リフォームの決定版
GNSピンネット工法



危ない!!
起きてからでは
遅すぎる!!

**地震で
崩落!!!**



欠損!!!

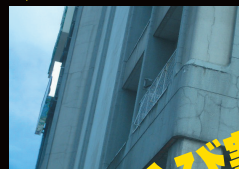

ひび割れ!!!



人物紹介



飯田順一 (60歳)

5階建てのビルのオーナー
定年退職してビルの管理をしている
悠々自適の生活だが
ビルの補修の時期を迎えて思案中



飯田洋子 (56歳)

飯田順一の妻
夫を信頼しつつ陰で
支えるしっかり者



松本洋子

飯田ビルの1階で
花屋を営んでいる
華やかで明るい美人

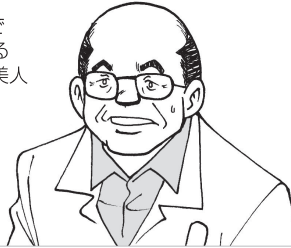

吉村

飯田ビルの隣に立つビルのオーナーで
1階理髪店の店主



理髪店の客

鈴木

飯田の同級生で
リフォーム会社を経営



田中

全国ビルリフォーム工事業協同組合で
『GNSピンネット工法』の
普及に努めている



- 作画：飯田わたる
- 企画・編集：(有)井田総合研究所
TEL.04-7183-2217
- 取材・シナリオ：(有)モア
- 編集協力：スタジオDIG
- 印刷・製本：(株)ジャパンアート

*落丁・乱丁本はお取替えいたします。禁無断転載。

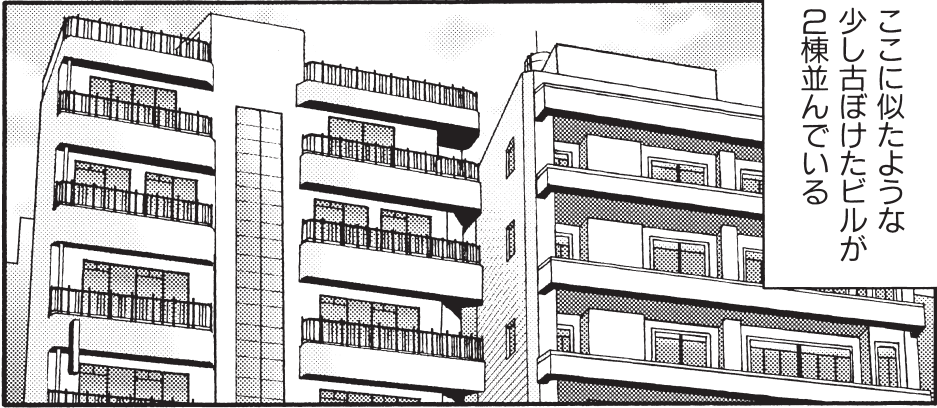

ここに似たような
少し古ぼけたビルが
2棟並んでいる

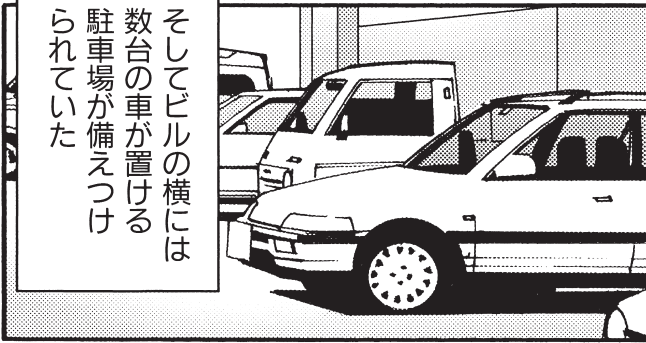

そしてビルの横には
数台の車が置ける
駐車場が備えつけ
られていた



1階はテナント
2階から5階までは
住宅になっている



オーナーさんは
このビルの5階に
住んでいます

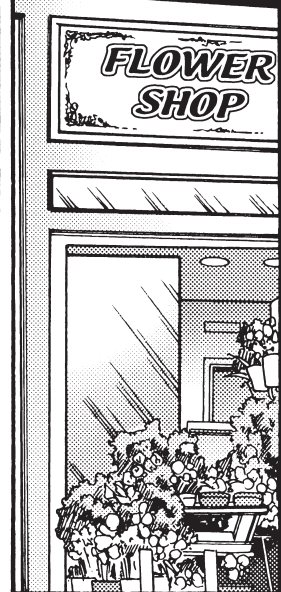

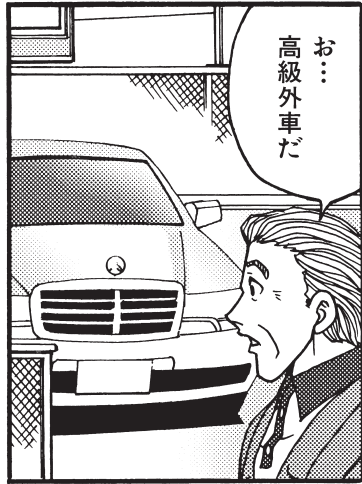
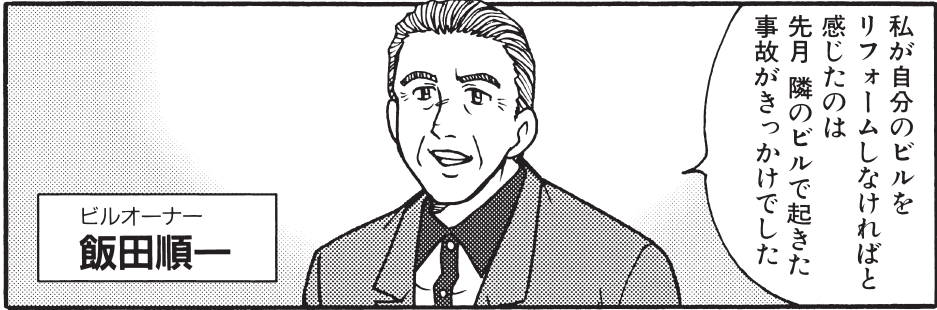

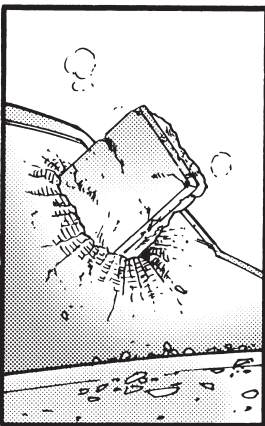
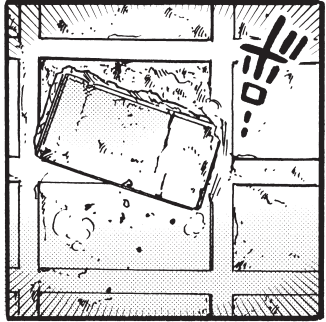
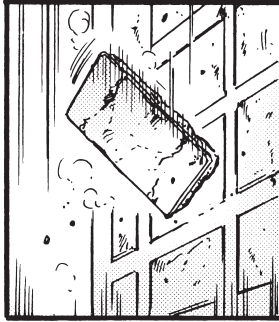
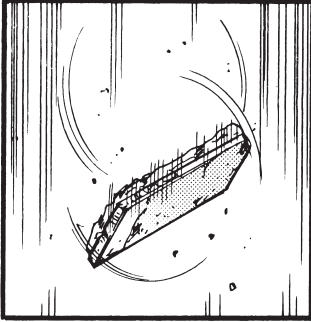

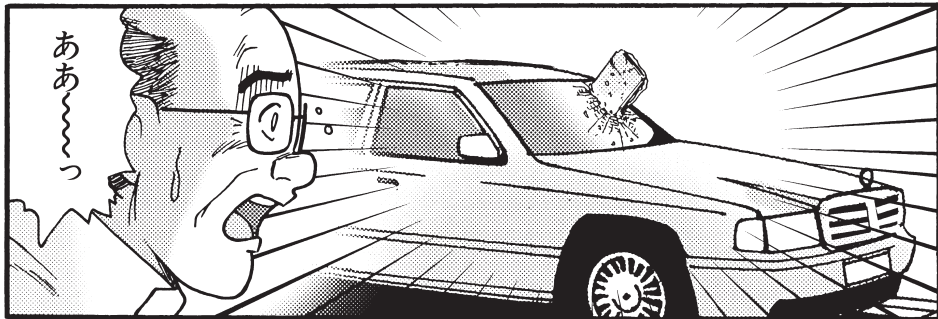

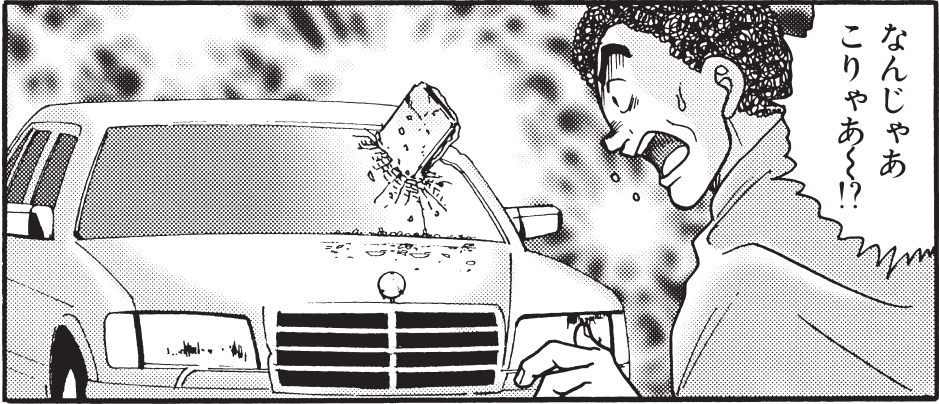

なんじゃあ
こりやあ〜!!



先代から
ゆずり受けた
大事な形見の
車なんだぞ!!

どうして
くれるんだ!?



申し訳
ございません
お客様…



い…いえっ
そんなつもりは…

慰謝料も含めて
しっかり責任
取ってもらおうぞ
いいな!?



弁償だけで
すます気か!?

も…もちろん
弁償させて
もらいます

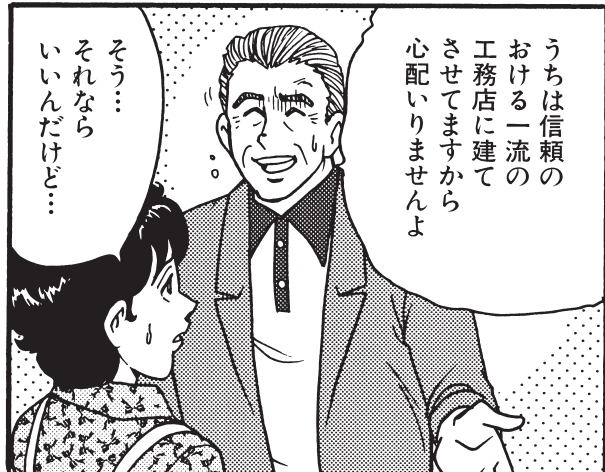

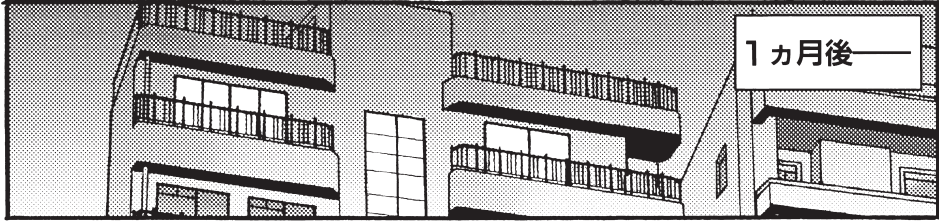

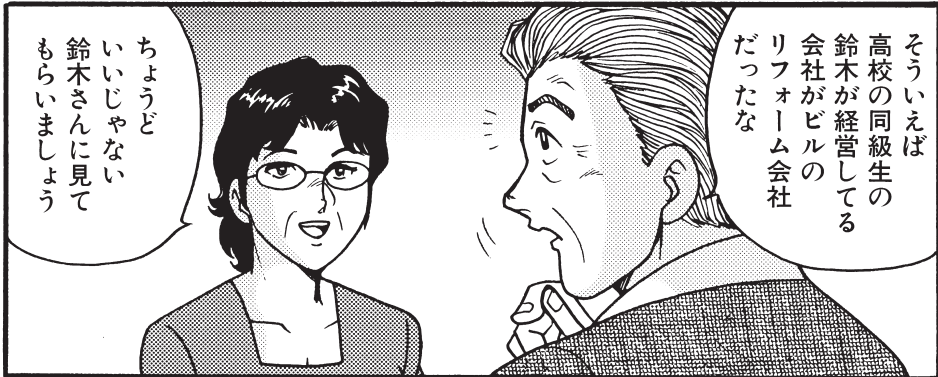

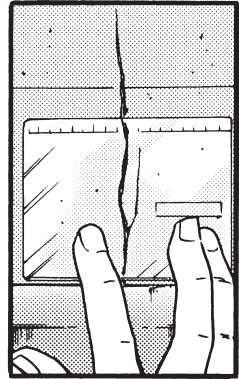
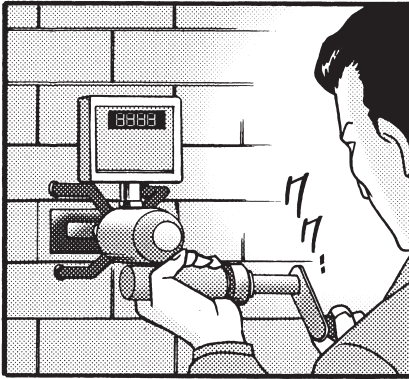

↑引張試験器(タイルを引っ張って強度を調べる) ↑打診棒(叩いた音で調べる)



←クラックスケール(ひび割れの幅などを計る) ※国の規定では0.4ニュートン以上の強度が求められている

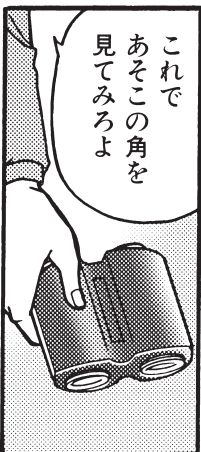

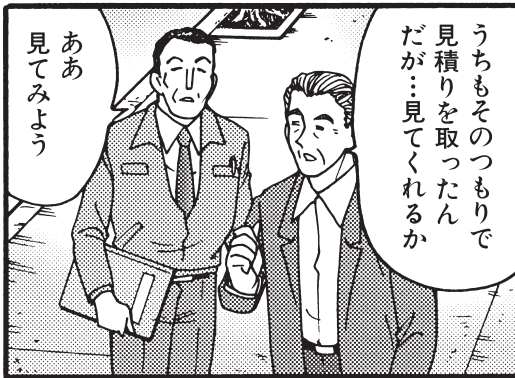

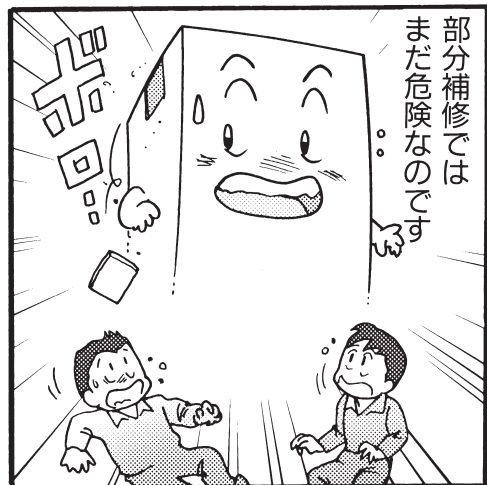

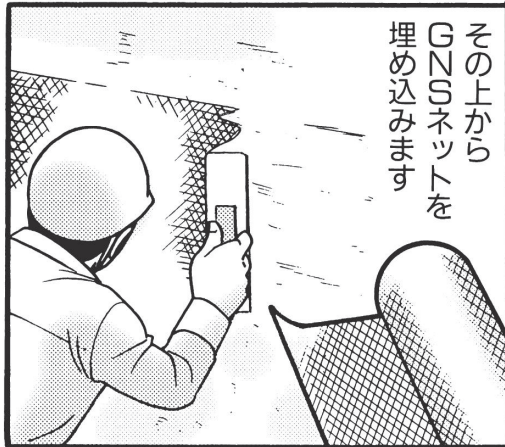
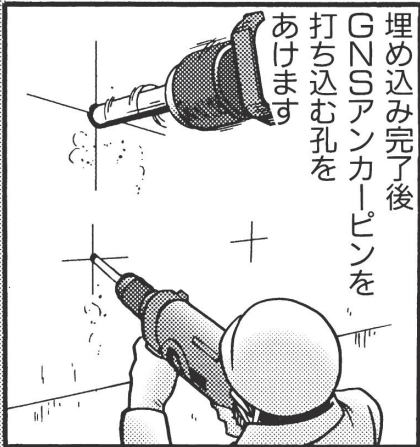

座金(ワッシャー)

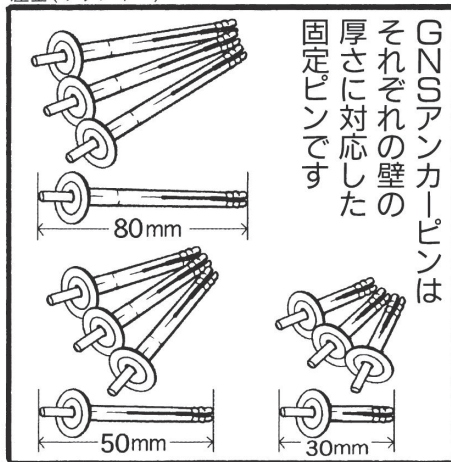
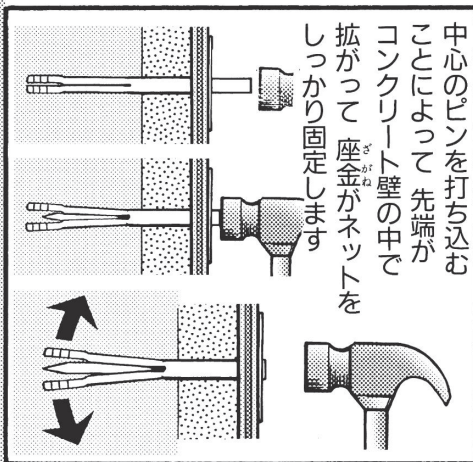

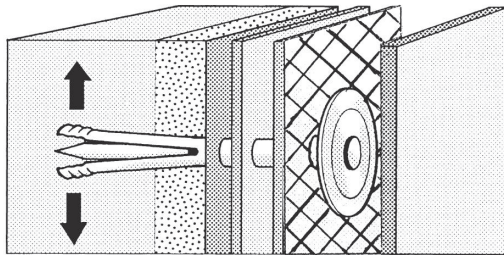

▲イメージ図

■ モルタル下地の改修例

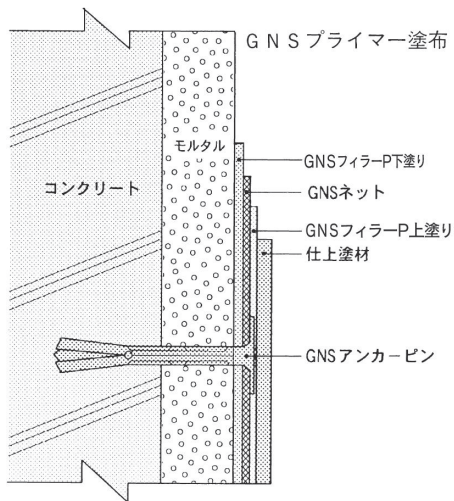

■ タイル下地の改修例

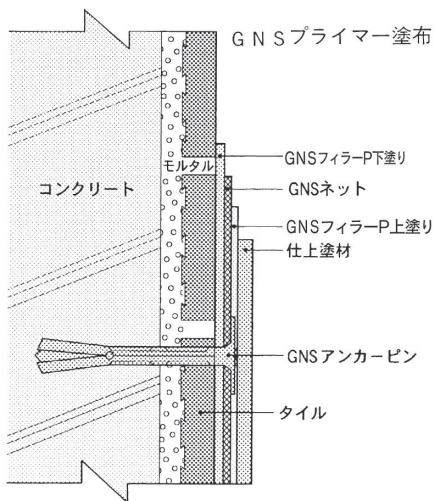

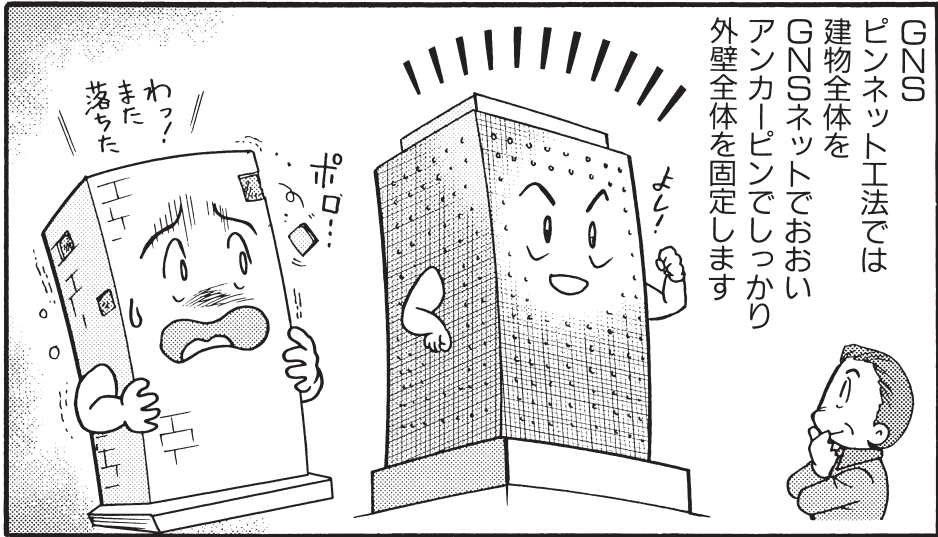

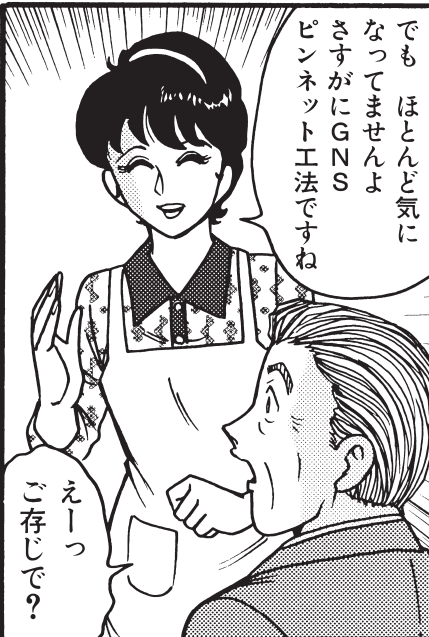
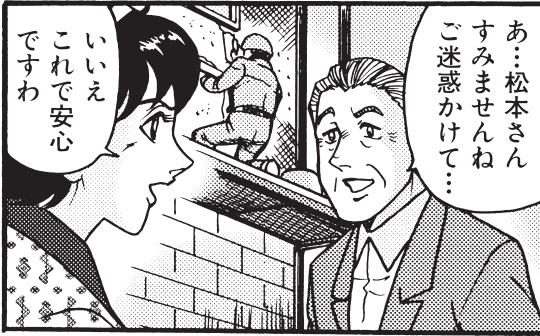

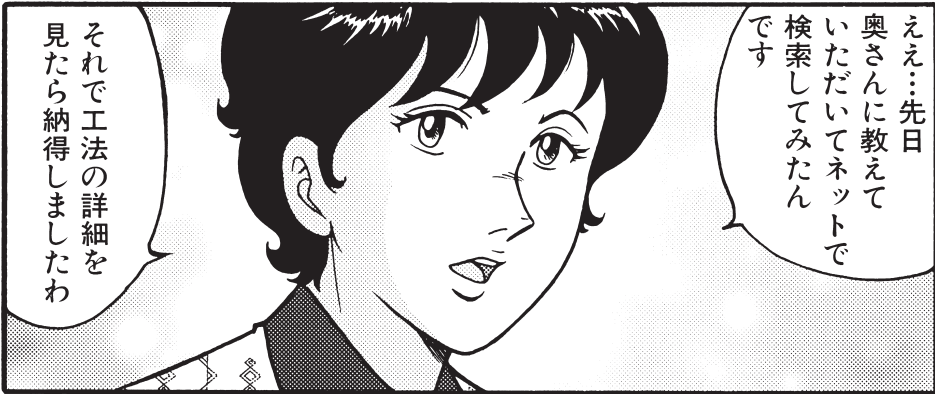

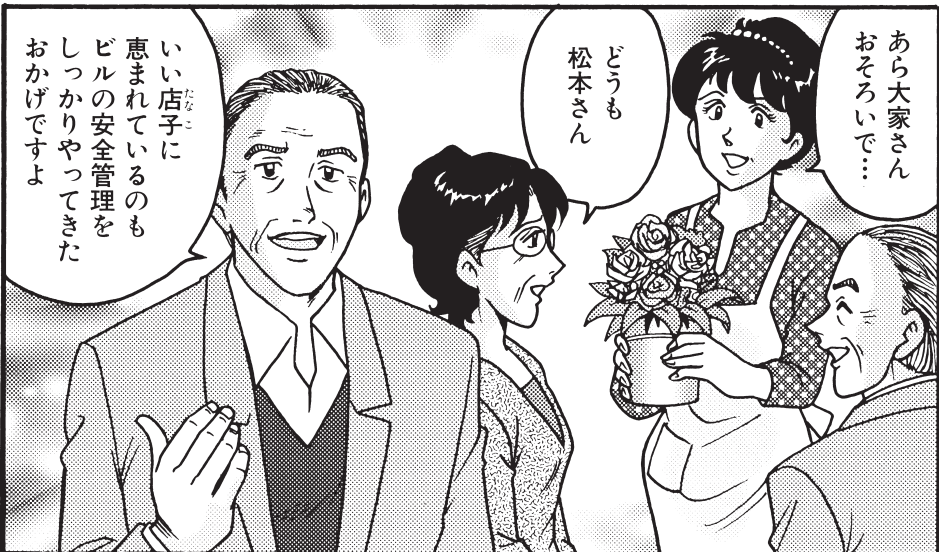
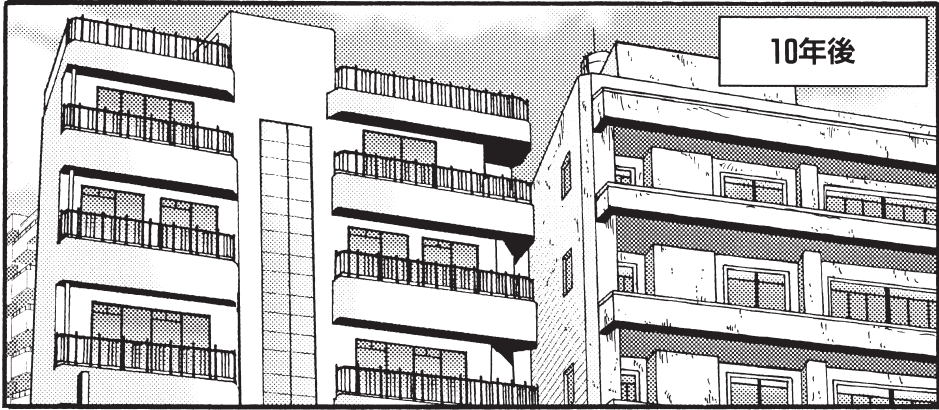

◆おわり◆

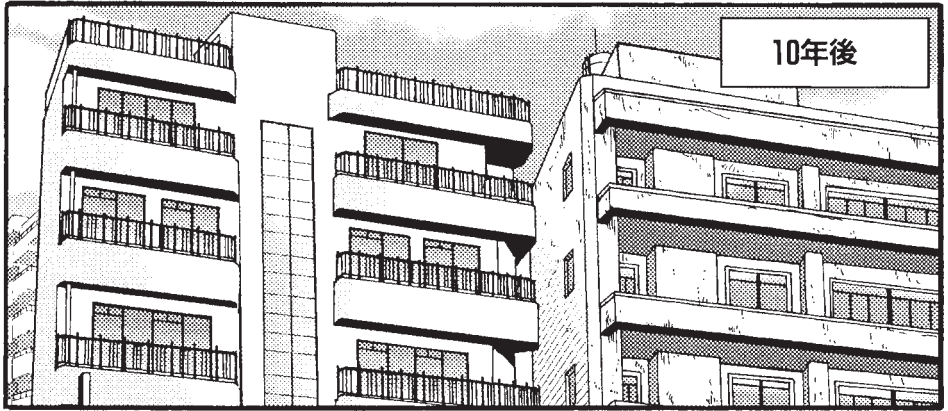

10年後



そうですね
頑張った甲斐が
ありましたね

うちはおまえの
言うとおり
あのとき頑張って
良かったよ



またお隣
壁が落ちたん
ですって

そうか…
大変だな

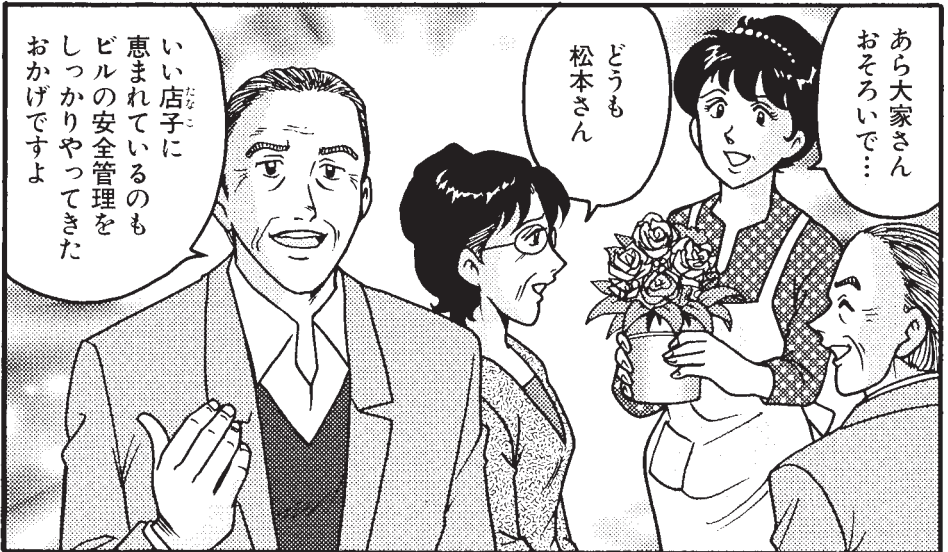

いい店たな子こに
恵たままれているのも
ビルの安全管理を
しっかりやってきた
おかげですよ

どうも
松本さん

あら大家さん
おそろいで…

◆おわり◆

GNSピンネット工法の特長

工事中の
騒音が少ない

塗装外壁の
ひび割れ抑制

工事中の
廃材が少ない

塗装の塗替で
壁が落ちない

外壁落下
10年間保証

建物の
寿命が延びる



建設大臣認定

実績と信頼に支えられる GNSピンネット工法

建築物の外壁落下防止及び補修技術に、一丸となって取り組んできたGNSピンネット工法の施工実績が評価され、建設技術評価証明書と保全技術・建設技術審査証明書をW取得しました。



建設技術評価証明書
(第96107号)



建設技術審査証明書
(BCJ-審査証明-43)

光清化成建設株式会社

〒102-0083 東京都千代田区麹町1丁目3-23

TEL.03-3264-1031 FAX.03-3264-1033